



Geoprobe® Model 6620DT

fast **FACTS**

6620DT Features

- 66 in. (1676 mm) probe cylinder stroke allows use of 60 in. (1,524 mm) probe rods
- Over 20 ton pulling capacity for today's larger sampling tools and deeper depths
- Equipped with the powerful GH60 Hammer
- Heavy Duty Undercarriage has a wider track that carries more weight, adds more torque, reduces ground pressure and handles greater tool weight
- Wireless remote control
- Built-in rotary spindle for concrete drilling, augering, and anchoring
- Equipped with a hydraulic winch for handling augers and tripping dual tube sampling tools
- Two-speed probe cylinder cycles from bottom to top in less than 5 seconds
- Powered by a four-cylinder, 54 Hp, liquid-cooled Kubota turbo diesel engine
- Hydraulic movement in all three axes allows easy probe alignment with tool string
- Auxiliary hydraulic ports provide power for remote equipment
- Compatible with Geoprobe® Tooling and Logging Equipment



Wireless Remote Control

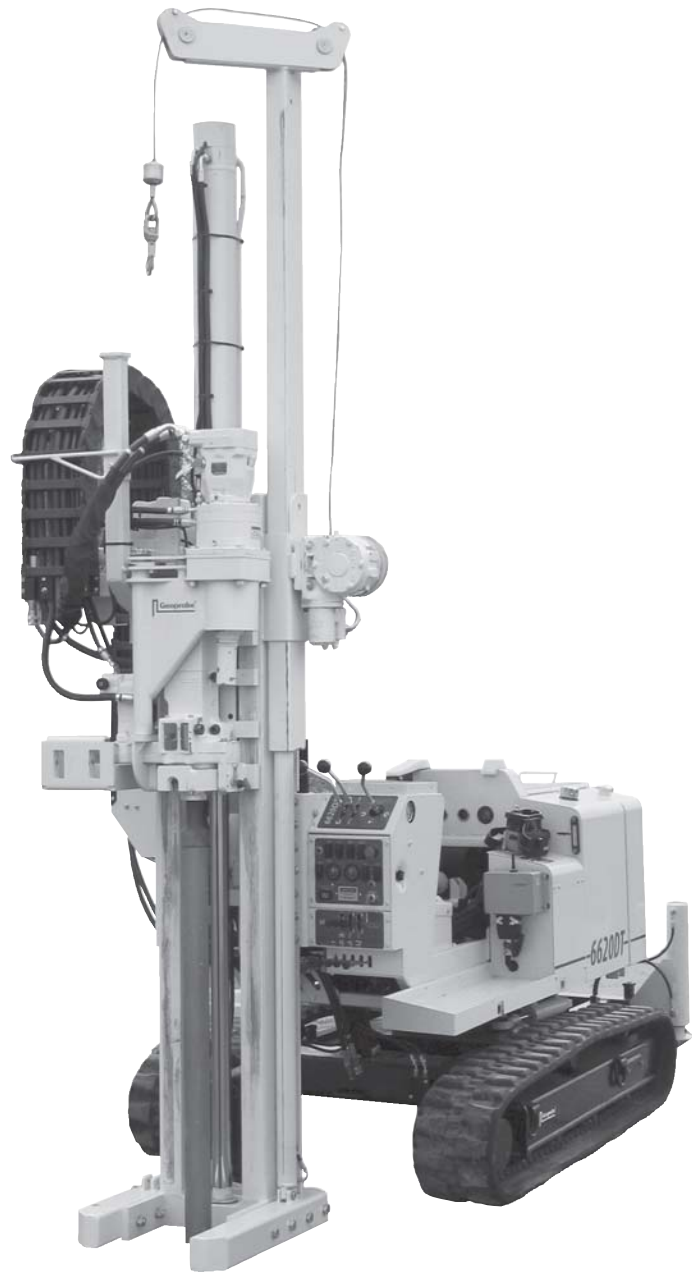

Geoprobe® Model 6620DT

with Augerhead Attachment

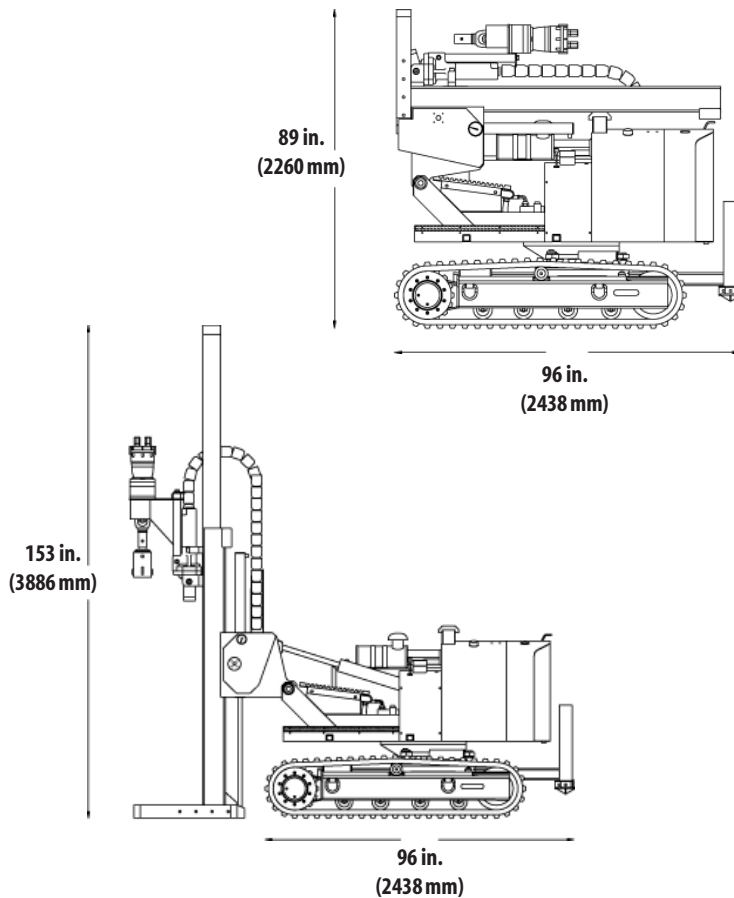

Model 6620DT Specifications

Stroke	66 in.	1676 mm
Weight	6,100 lb.	2767 kg
Width	60 in.	1524 mm
Length (folded)	96 in.	2438 mm
Height (folded)	89 in.	2260 mm
Height (unfolded)	153 in.	3886 mm
Lateral Movement (side-to-side)	33 in.	838 mm
Foot Travel	39 in.	991 mm
Extension	15 in.	381 mm
Down Force	35,000 lb.	160 kN
Retraction Force	47,000 lb.	214 kN
Hydraulic Pressure (system)	2,850 psi	196 bar
Hydraulic Flow Rate (system)	30 gpm	114 Lpm
Hammer System	GH60	
Percussion Rate	32 Hz	
Torque (hammer motor)	560 ft. lb.	759 Nm
Rotation Rate (hammer motor)	240 rpm (bi-directional)	
Fuel Capacity (diesel)	15 gal	57 L
Engine (diesel)	Kubota, 4-cylinder turbo	
Engine Power	54 hp	40 Kw
Outrigger Extension	16 in.	406 mm

Augerhead Specifications

Torque (high torque/low speed)	3,000 ft. lb.	4067 Nm
Torque (low torque/high speed)	1,500 ft. lb.	2034 Nm
Hex adapter	1-5/8 in.	41 mm
Rotation speed (low speed/high torque)	0-105rpm	
Rotation speed (high speed/low torque)	0-150rpm	

Geoprobe Systems

Geoprobe® Model PC111

Geoprobe® Model 540B

Geoprobe® Model 6610DT with GA3000 Augerhead Attachment

Geoprobe® Model 6610DT with DH66 Automatic Drophammer

Geoprobe® Model 54DT

The 6620DT is equipped for easy accessory installation if the new hydraulic winch option is added to the machine configuration.



fast FACTS

We have developed this Fast Facts document to allow you the ability to quickly compare the features and capabilities of various probe machines offered by Geoprobe Systems® ... the direct push innovators. This document is not a final purchasing quotation. If you are interested in a specific Geoprobe® direct push system, please call us at **1-800-436-7762** for a formal, specialized quotation which includes all the details required for purchasing your Geoprobe® system.



601 N. Broadway • Salina, KS 67401 • 1-800-436-7762
www.geoprobe.com