



Geoprobe® Model 540MT

fast **FACTS**

540MT Features

- 54 inch (1372 mm) stroke
- Supplies 25,000 lb. (111 kN) of pulling capacity
- Performs same operations as larger probes including concrete drilling, soil and groundwater sampling, and conductivity logging
- Weighs less than 965 lb. (438 kg)
- Front transport wheels are adjustable in-and-out to clear narrow passageways
- Rear transport wheel and handle pivot 360 degrees to maneuver probe in extremely close quarters
- Easily attaches to remote power unit by way of hydraulic lines with quick connects
- Removable outriggers enhance stability while probing
- Powered by a PortaCo® Hydraulic Power Unit
- Compatible with most Geoprobe Tooling and Logging Equipment



Geoprobe® Model 540MT

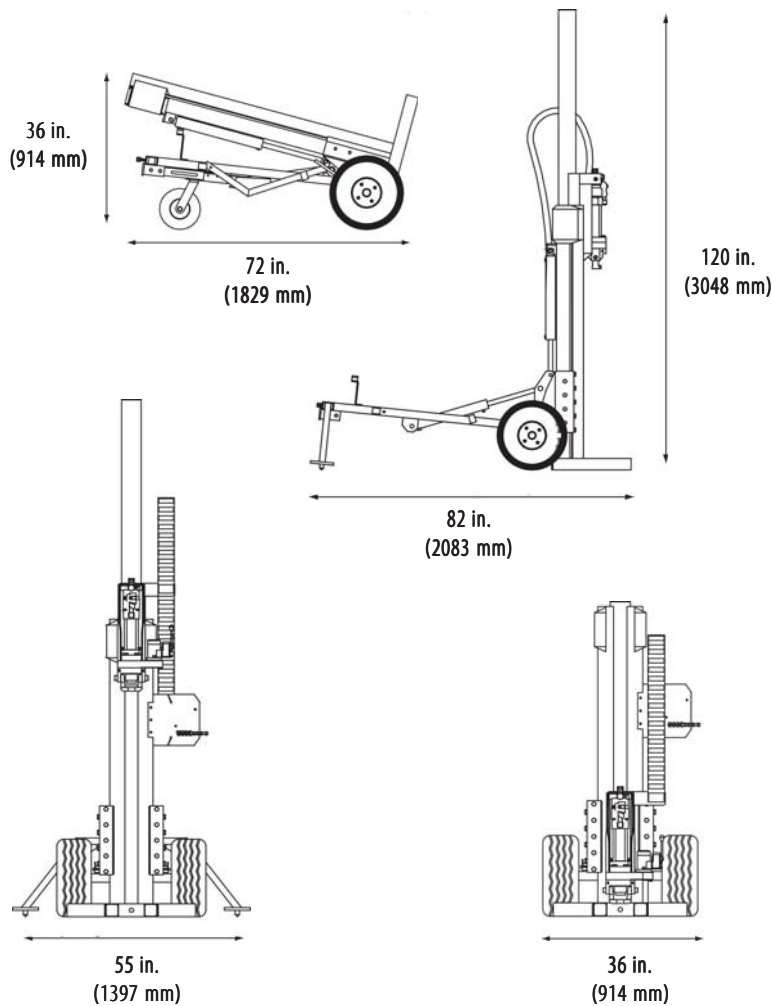

Model 540MT Specifications

Stroke	54 in.	1372 mm
Weight	965 lb.	438 kg
Width	36 in.	914 mm
Length (folded)	72 in.	1829 mm
Length (unfolded)	82 in.	2083 mm
Height (folded)	29 in.	737 mm
Height (unfolded)	120 in.	3048 mm
Probe Cylinder Diameter	4.0 in.	102 mm
Down Force	18,000 lb.	80 kN
Retraction Force	25,000 lb.	111 kN
Hydraulic Pressure	2,000 psi	138 bar
Hydraulic Flow Rate	10 gpm	38 Lpm
Hammer System	GH-40	
Percussion Rate	30 Hz	
Torque	345 ft. lb.	468 Nm
Rotation Rate (bi-directional)	125 rpm	

PortaCo® Inc. Compact, Hydraulic Power Unit

Hydraulic Flow: 10 gpm (38 Lpm) at 2000 psi (138 bar)
 Powered by an 18 Hp Briggs & Stratton electric-start engine
 Engine operates on unleaded gasoline
 (Diesel available by request)
 Compact Size: 35 in. long x 29 in. wide x 32 in. high
 (889 x 737 x 813 mm)
 Weight: 320 lb. (145 kg)

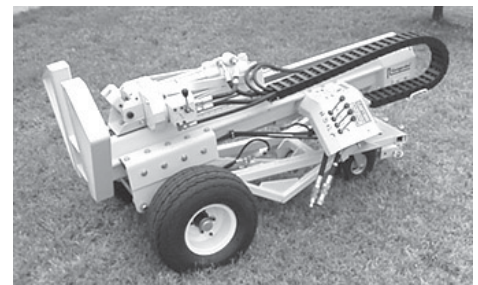

fast FACTS

We have developed this Fast Facts document to allow you the ability to quickly compare the features and capabilities of various probe machines offered by Geoprobe Systems® ... the direct push innovators. This document is not a final purchasing quotation. If you are interested in a specific Geoprobe® direct push system, please call us at **1-800-436-7762** for a formal, specialized quotation which includes all the details required for purchasing your Geoprobe® system.



601 N. Broadway • Salina, KS 67401 • 1-800-436-7762
www.geoprobe.com

Geoprobe Systems

